

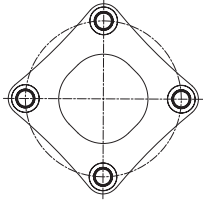

**Technical data**

The following lamina types are to be distinguished with RIGIFLEX®-N:

Size 35 – 65  
(lamina with 4 holes)



Size 75 – 160  
(lamina with 6 holes)

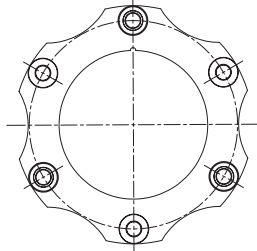

Size 166 – 406  
(lamina with 6 holes)

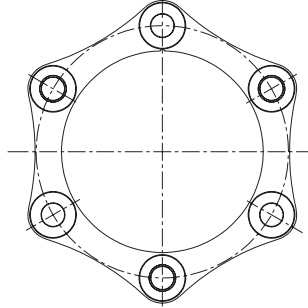

Size 168 – 408  
(lamina with 8 holes)

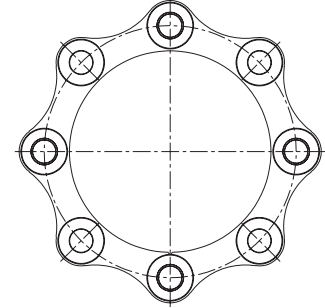

RADEX®-N

Torques and displacements											
Size	Lamina shape	Torques [Nm]			Angular displacement ± Kw <sup>1)</sup> [°]	Axial displacement ± Ka [mm]	Perm. displacements				
		TKN	TK max	TKW			Radial ± Kr [mm]				
							E=100	E=140	E=180	E=200	E=250
35		130	260	65	0.7	1.2	0.90	1.40	-	-	-
50	lamina with 4 holes	270	540	135	0.7	1.4	0.77	1.26	-	-	-
65		550	1100	275	0.7	1.5	0.75	1.23	1.72	-	-
75		1100	2200	550	0.7	1.8	0.73	1.22	1.71	-	-
85		1900	3800	950	0.7	2.1	-	1.14	1.62	1.87	2.48
110		3500	7000	1750	0.7	2.4	-	1.05	1.54	1.78	2.39
120		5750	11500	2875	0.7	2.6	-	1.00	1.49	1.73	2.35
140		10500	21000	5250	0.7	3.3	-	-	-	1.55	2.16
160		16000	32000	8000	0.7	3.8	-	-	-	-	1.99
166	lamina with 6 holes	19000	38000	9500	0.7	3.7					
196		22500	45000	11250	0.7	4.2					
216		32000	64000	16000	0.7	4.5					
256		52500	105000	26250	0.7	5.2					
306		86000	172000	43000	0.7	6.0					
346		135000	270000	67500	0.7	6.7					
406		210000	420000	105000	0.7	7.5					
168		25000	50000	12500	0.5	2.6					
198		30000	60000	15000	0.5	2.8					
218		42500	85000	21500	0.5	3.0					
258	lamina with 8 holes	70000	140000	35000	0.5	3.5					
308		115000	230000	57500	0.5	4.0					
348		180000	360000	90000	0.5	4.5					
408		280000	560000	140000	0.5	5.0					

<sup>1)</sup> Angular displacement each lamina set

If axial, angular and radial shaft displacement arises in parallel please note the following table:

Size	Permissible angular displacement							
	0	0.1	0.2	0.3	0.4	0.5	0.6	0.7
	Permissible axial displacement							
35	1.20	1.00	0.85	0.74	0.60	0.40	0.20	0.00
50	1.40	1.20	1.00	0.80	0.60	0.40	0.20	0.00
65	1.50	1.29	1.07	0.86	0.64	0.43	0.22	0.00
75	1.80	1.54	1.29	1.03	0.77	0.52	0.26	0.00
85	2.10	1.80	1.50	1.20	0.90	0.60	0.30	0.00
110	2.40	2.06	1.71	1.37	1.03	0.69	0.34	0.00
120	2.60	2.23	1.86	1.48	1.11	0.74	0.37	0.00
140	3.30	2.83	2.36	1.88	1.41	0.94	0.47	0.00
160	3.80	3.26	2.71	2.17	1.63	1.09	0.54	0.00
166	3.70	3.17	2.64	2.12	1.59	1.06	0.53	0.00
196	4.20	3.60	3.00	2.40	1.80	1.20	0.60	0.00
216	4.50	3.86	3.21	2.57	1.93	1.29	0.64	0.00
256	5.20	4.46	3.71	2.97	2.23	1.49	0.74	0.00
306	6.00	5.14	4.29	3.43	2.57	1.72	0.86	0.00
346	6.75	5.79	4.82	3.86	2.89	1.93	0.96	0.00
406	7.50	6.43	5.36	4.28	3.21	2.14	1.07	0.00
168	2.60	2.08	1.56	1.04	0.52	0.00	-	-
198	2.80	2.24	1.68	1.12	0.56	0.00	-	-
218	3.00	2.40	1.80	1.20	0.60	0.00	-	-
258	3.50	2.80	2.10	1.40	0.70	0.00	-	-
308	4.00	3.20	2.40	1.60	0.80	0.00	-	-
348	4.50	3.60	2.70	1.80	0.90	0.00	-	-
408	5.00	4.00	3.00	2.00	1.00	0.00	-	-

Lamina couplings  
RIGIFLEX®-N

RIGIFLEX®-HP

**Technical data**

Permissible speeds and stiffness										
Size	Max. speed [rpm]	each lamina set		ct [Nm/rad] for complete coupling with mounting length E						
		cw [Nm/rad]	ct x 10 <sup>6</sup> [Nm/rad]	E=100	E=140	E=180	E=200	E=250		
35	23000	170	0.056	65020	56700	-	-	-		
50	18000	490	0.27	73953	63990	-	-	-		
65	13600	260	0.5	146022	129938	117046	-	-		
75	12400	1000	0.67	306145	278381	255234	-	-		
85	11000	1500	0.9	-	406641	369429	353265	318433		
110	9000	1500	1.5	-	664284	637587	625028	595693		
120	8000	3000	2.0	-	1798018	1637553	1567602	1416348		
140	6400	10000	3.5	-	-	-	2363340	2226630		
160	5600	10350	6.9	-	-	-	-	2654894		
166	5600	26800	13.0	Mounting dimension E as specified by the customer					-	-
196	5200	35800	17.0						-	-
216	4600	41500	19.0						-	-
256	3900	65000	31.0						-	-
306	3300	112000	55.0						-	-
346	2900	205000	79.0						-	-
406	2500	276000	125.0						-	-
168	5600	44300	20.0						-	-
198	5200	82200	26.0						-	-
218	4600	90000	30.0						-	-
258	3900	138000	49.0						-	-
308	3300	234000	83.0						-	-
348	2900	416000	125.0						-	-
408	2500	562000	200.0						-	-

cw = angular stiffness  
ct = torsion spring stiffness

Weights and mass moments of inertia														
Size	Hub (max. bore)		Spacer complete [kg]					Spacer complete [kgm <sup>2</sup> ]						
	[kg]	[kgm <sup>2</sup> ]	E=100	E=140	E=180	E=200	E=250	E=100	E=140	E=180	E=200	E=250		
35	0.60	0.0007	1.030	1.120	-	-	-	0.00040	0.00050	-	-	-		
50	0.92	0.001019	2.262	2.442	-	-	-	0.00256	0.00263	-	-	-		
65	2.7	0.00541	3.922	4.183	4.445	-	-	0.00810	0.00830	0.00828	-	-		
75	2.4	0.00566	4.482	4.842	5.202	-	-	0.01143	0.01191	0.01239	-	-		
85	3.7	0.01135	-	7.154	7.548	7.746	8.239	-	0.02364	0.02427	0.02459	0.02538		
110	6.7	0.03222	-	12.492	13.478	13.972	15.205	-	0.06291	0.06540	0.06665	0.06976		
120	9.2	0.05238	-	-	17.324	17.842	19.137	-	-	0.10314	0.10458	0.10818		
140	18.2	0.15175	-	-	-	32.530	34.325	-	-	-	0.31901	0.32845		
160	29.9	0.33890	-	-	-	-	52.458	-	-	-	-	0.68640		
166	28.0	0.32	Mounting dimension E as specified by the customer										-	-
196	37.0	0.554											-	-
216	50.0	0.85											-	-
256	95.0	2.35											-	-
306	138.0	4.55											-	-
346	215.0	9.75											-	-
406	310.0	18.95											-	-
168	30.0	0.33											-	-
198	40.0	0.56											-	-
218	52.0	0.88											-	-
258	99.0	2.43											-	-
308	142.0	4.78											-	-
348	222.0	9.83											-	-
408	325.0	19.22											-	-

### Standard type A



For legend of pictogram please refer to flapper on the cover

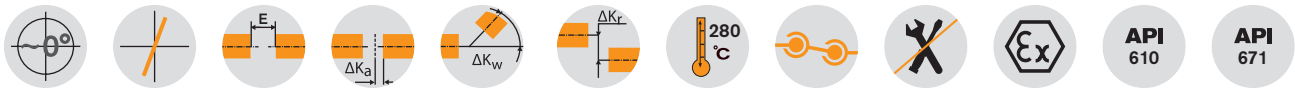

### Components

Size 35

Size 50 - 408

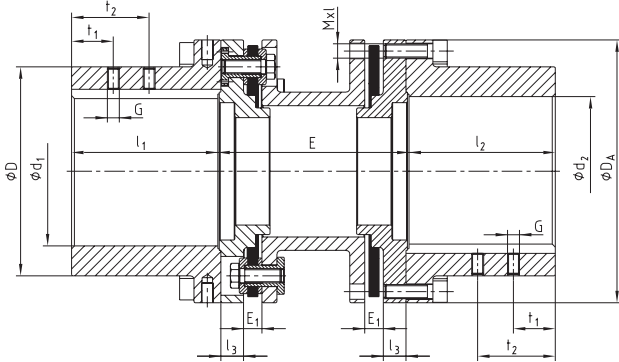
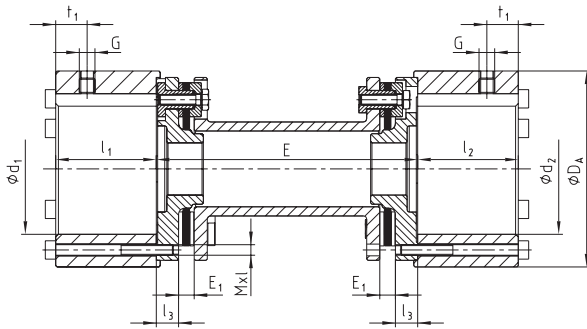

RIGIFLEX®-N type A																			
Size	Torques [Nm]			Max. finish bore	Dimensions [mm]													Screws DIN EN ISO 4762	
	T <sub>KN</sub>	T <sub>K max</sub>	T <sub>KW</sub>		d <sub>1</sub> , d <sub>2</sub>	D	D <sub>A</sub>	l <sub>1</sub> , l <sub>2</sub>	l <sub>3</sub>	G	t <sub>1</sub>	t <sub>2</sub>	E <sub>1</sub>	E <sup>1)</sup>				MxI	T <sub>A</sub> [Nm]
35	130	260	65	50	-	75	38.5	8.5	M6	15	-	6	100	140	-	-	-	M4x45	4.1
50	270	540	135	50	70	95	50	12	M6	10	-	9	100	140	-	-	-	M6x22	14
65	550	1100	275	70	100	126	63	12	M8	20	-	11	100	140	180	-	-	M6x25	14
75	1100	2200	550	75	105	138	62.5	12	M8	20	-	11	100	140	180	-	-	M8x30	35
85	1900	3800	950	90	120	156	72.5	15	M10	20	-	12	-	140	180	200	250	M8x30	35
110	3500	7000	1750	110	152	191	87	18	M10	25	-	12	-	140	180	200	250	M10x35	69
120	5750	11500	2875	120	165	213	102	20	M12	25	-	12	-	-	180	200	250	M12x40	120
140	10500	21000	5250	150	200	265	126	25	M12	30	-	15	-	-	-	200	250	M16x50	295
160	16000	32000	8000	165	230	305	145	31	M12	30	-	15	-	-	-	-	250	M16x55	295
166	19000	38000	9500	165	230	305	155	31	M16	30	70	17					M20x50	560	
196	22500	45000	11250	195	260	330	185	32	M16	40	90	24					M20x50	560	
216	32000	64000	16000	210	285	370	205	32	M20	50	110	26					M20x65	560	
256	52500	105000	26250	260	350	440	245	38	M20	70	130	31					M24x80	970	
306	86000	172000	43000	305	400	515	295	43	M24	70	130	36					M27x100	1450	
346	135000	270000	67500	350	460	590	335	55	M24	95	175	45					M30x110	1950	
406	210000	420000	105000	405	530	675	395	58.5	M24	95	175	50	According to customer specification				M36x130	3300	
168	25000	50000	12500	165	230	305	155	31	M16	30	70	17					M20x50	560	
198	30000	60000	15000	195	260	330	185	32	M16	40	90	24					M20x50	560	
218	42500	85000	21500	210	285	370	205	32	M20	50	110	26					M20x65	560	
258	70000	140000	35000	260	350	440	245	38	M20	70	130	31					M24x80	970	
308	115000	230000	57500	305	400	515	295	43	M24	70	130	36					M27x100	1450	
348	180000	360000	90000	350	460	590	335	55	M24	95	175	45					M30x110	1950	
408	280000	560000	140000	405	530	675	395	58.5	M24	95	175	50					M36x130	3300	

<sup>1)</sup> Other shaft distance dimensions available on request.  
For selection of coupling see page 18 et seqq. Assembly instructions KTR standard 47410 available at [www.ktr.com](http://www.ktr.com).

Ordering example:	RIGIFLEX®-N 120	A	Ø 100	Ø 120	200
	Coupling size	Type	Bore d <sub>1</sub>	Bore d <sub>2</sub>	Shaft distance dimension E

RADEX®-N

Lamina couplings

RIGIFLEX®-N

RIGIFLEX®-HP

### Standard type A-J

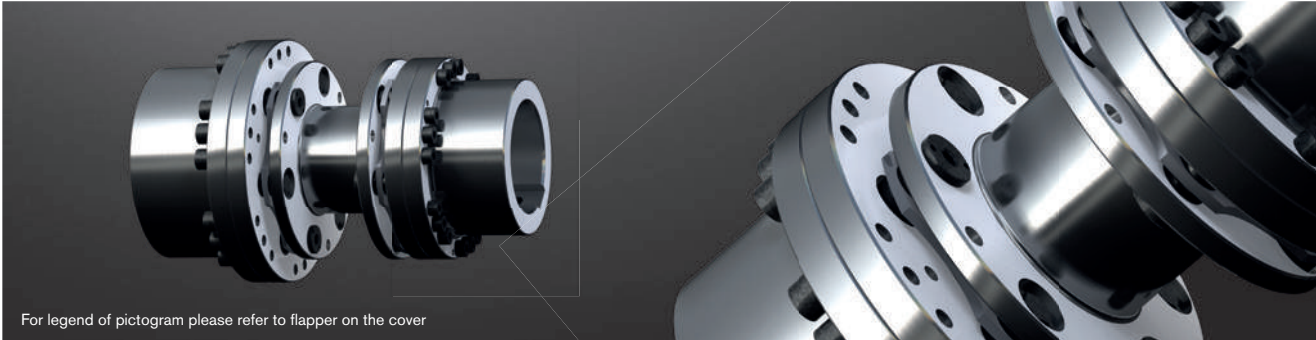

For legend of pictogram please refer to flapper on the cover



#### Components

#### Size 50 - 140

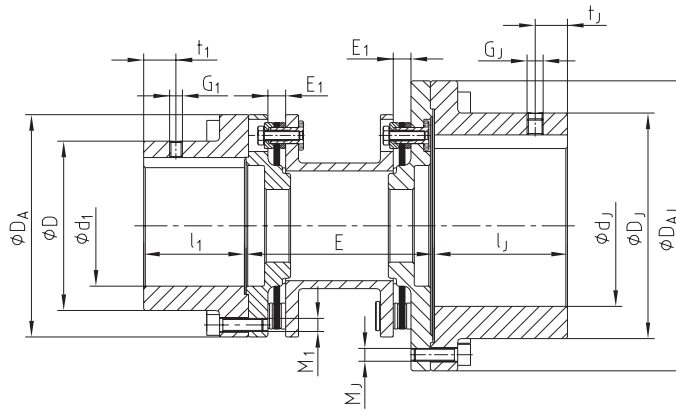

RIGIFLEX®-N type A-J																									
Size	Torques [Nm]			Max. finish bore		Dimensions [mm]														Screws DIN EN ISO 4762					
	TKN	TK max	TKW	d1	d2	D	DA	l1	DJ	DAJ	lJ	G1	t1	GJ	tJ	E1	E <sup>1)</sup>				M1	TA [Nm]	MJ	TA [Nm]	
50	270	540	135	50	70	70	95	50	100	126	63	M6	10	M8	20	9	100	140	-	-	-	M6	14	M6	14
65	550	1100	275	70	90	100	126	63	120	156	72.5	M8	20	M10	20	11	100	140	180	-	-	M6	14	M8	35
75	1100	2200	550	75	100	105	138	62.5	140	180	83	M8	20	M10	20	11	100	140	180	-	-	M8	35	M8	35
85	1900	3800	950	90	110	120	156	72.5	152	191	87.5	M10	20	M10	25	12	-	140	180	200	250	M8	35	M10	69
110	3500	7000	1750	110	150	152	191	87	200	265	127	M10	25	M12	30	12	-	140	180	200	250	M10	69	M16	295
120	5750	11500	2875	120	165	165	213	102	230	305	147	M12	25	M12	30	12	-	-	180	200	250	M12	120	M16	295
140	10500	21000	5250	150	195	200	265	126	260	330	186	M12	30	M16	40/90	15	-	-	-	200	250	M16	295	M20	560

<sup>1)</sup> Other shaft distance dimensions available on request.  
For selection of coupling see page 18 et seqq. Assembly instructions KTR standard 47410 available at [www.ktr.com](http://www.ktr.com).

#### Other types:

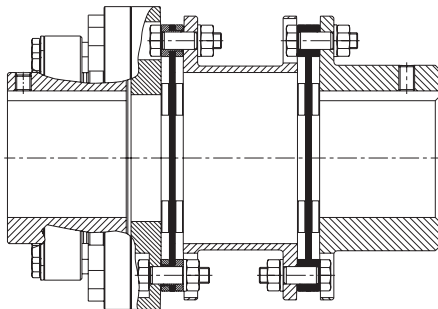

For RADEX®-N with integrated slipping unit see dimension sheet 699206

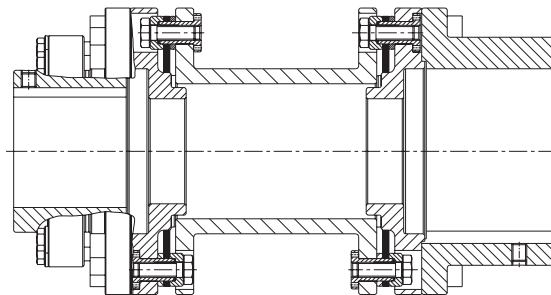

For RIGIFLEX®-N with integrated slipping unit see dimension sheet 698869

Ordering example:	RIGIFLEX®-N 85	A-J	Ø 80	Ø 120	200
	Coupling size	Type	Bore d <sub>1</sub>	Bore d <sub>J</sub>	Shaft distance dimension E

**Standard type A-H**

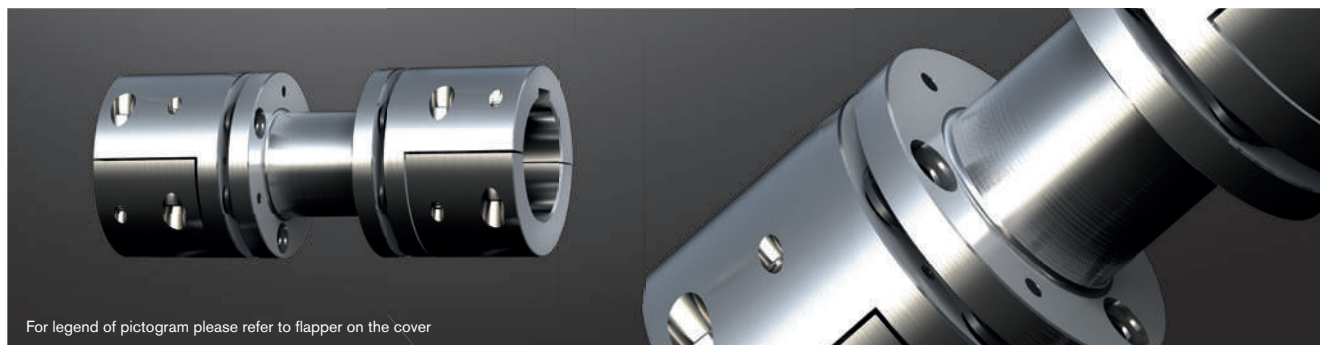

For legend of pictogram please refer to flapper on the cover

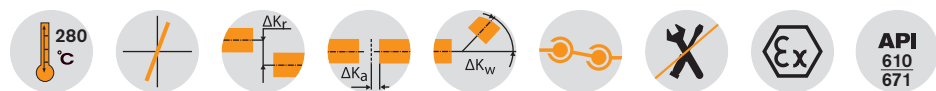

RADEX®-N

**Components**

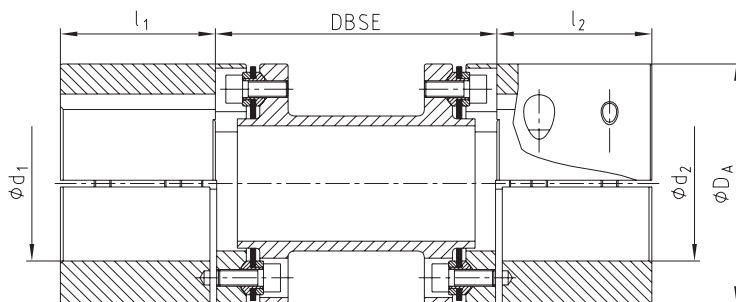

Lamina couplings

RIGIFLEX®-N

RIGIFLEX®-N type A-H											
Size	Torques [Nm]		Max. finish bore [mm]		Dimensions [mm]						
	T <sub>KN</sub>	T <sub>K max</sub>	d <sub>1</sub> , d <sub>2</sub>	D <sub>A</sub>	l <sub>1</sub> , l <sub>2</sub>	Standard shaft distance dimension DBSE <sup>1)</sup>			Perm. axial displacement	Perm. angular displacement (each lamina set [°])	
46	90	180	42	69	45					+/- 1.4	1.0
56	255	510	55	85	55	100				+/- 1.2	0.7
66	450	900	65	105	65		140	180	250	+/- 1.6	0.7
76	975	1950	75	124	75					+/- 1.8	0.7
86	1500	3000	85	145	85	-				+/- 2.2	0.7
106	2400	4800	105	168	105					+/- 2.4	0.7

<sup>1)</sup> Other shaft distance dimensions (DBSE) available on request

**Benefits of type A-H:**

- Hub type 7.6 - half shell hub
- Easy and quick radial assembly and disassembly
- Type according to API 610 and 671 (please consider exceptions)
- Drop-out protection of spacer with fracture of laminae following API 671



**Ordering example:**

RIGIFLEX®-N 66	A-H	Ø 42	Ø 48	140
Coupling size	Type	Bore d <sub>1</sub>	Bore d <sub>2</sub>	Shaft distance dimension DBSE

# RIGIFLEX®-HP C

## High-performance steel lamina couplings

### Flange connection

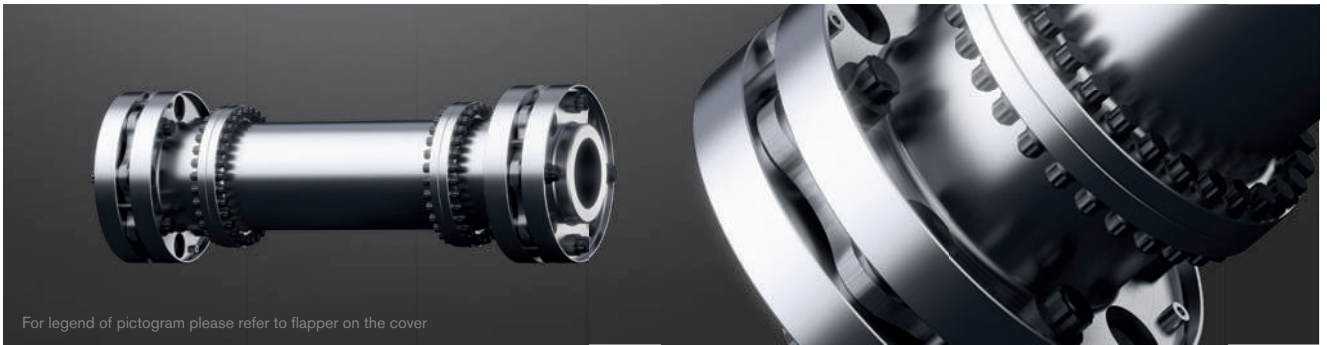

For legend of pictogram please refer to flapper on the cover



### Components

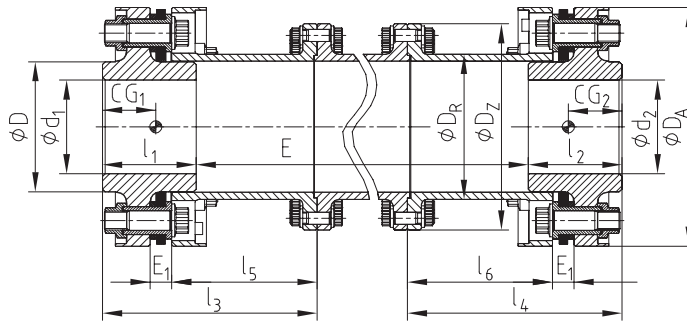

RIGIFLEX®-HP type C														
Size	Torques [Nm]		Max. finish bore	Dimensions [mm]										
	T <sub>KN</sub>	T <sub>K max</sub>		d <sub>1</sub> , d <sub>2</sub>	D	D <sub>A</sub>	D <sub>Z</sub>	D <sub>R</sub>	E <sub>1</sub>	E	E <sub>min</sub>	CG <sub>1</sub> , CG <sub>2</sub> <sup>2)</sup>	l <sub>1</sub> , l <sub>2</sub>	l <sub>3</sub> , l <sub>4</sub>
158	20000	26000	85	119	220	195	135	17	According to customer specification	335	46	85	189	130
168	30000	39000	100	139	255	220	155	23		395	55	100	229	155
188	38000	49400	105	147	265	235	165	23		375	55	105	229	155
208	50000	65000	120	168	298	245	186	23		350	57	120	229	155
228	59000	76700	125	178	315	270	199	33		425	65	125	265	175
248	72000	93600	140	196	335	300	217	33		395	67	140	265	175
278	115000	149500	160	225	380	335	248	33		355	70	160	265	175
318	180000	234000	180	252	445	370	280	48		495	88	180	348	225
358	253000	328900	210	295	500	415	326	48		435	93	210	348	225
388	330000	429000	235	330	545	464	362	48		400	97	235	348	225

Technical data								
Size	Max. speed [rpm]	Perm. displacements			Stiffness figures			
		Angular <sup>1)</sup> ± K <sub>w</sub> [°]	Axial ± K <sub>a</sub> [mm]	Radial <sup>2)</sup> ± K <sub>r</sub> [mm]	each lamina set c <sub>l</sub> [Nm/rad]	Spacer c <sub>lR</sub> [Nm · mm/rad]	Coupling complete <sup>2)</sup> c <sub>lE</sub> = 457.2 [Nm/rad]	
158	17300	0.25	3.0	2.30	13.0 · 10 <sup>6</sup>	839 · 10 <sup>6</sup>	1.04 · 10 <sup>6</sup>	
168	14900	0.25	3.0	2.32	18.0 · 10 <sup>6</sup>	1535 · 10 <sup>6</sup>	1.79 · 10 <sup>6</sup>	
188	14400	0.25	3.3	2.37	28.0 · 10 <sup>6</sup>	1974 · 10 <sup>6</sup>	2.23 · 10 <sup>6</sup>	
208	12800	0.25	3.8	2.50	35.0 · 10 <sup>6</sup>	2876 · 10 <sup>6</sup>	3.15 · 10 <sup>6</sup>	
228	12100	0.25	4.0	2.44	39.5 · 10 <sup>6</sup>	4123 · 10 <sup>6</sup>	5.06 · 10 <sup>6</sup>	
248	11400	0.25	4.2	2.58	60.0 · 10 <sup>6</sup>	5410 · 10 <sup>6</sup>	5.51 · 10 <sup>6</sup>	
278	10000	0.25	4.5	2.75	80.0 · 10 <sup>6</sup>	8592 · 10 <sup>6</sup>	7.94 · 10 <sup>6</sup>	
318	8500	0.25	5.2	2.70	105.0 · 10 <sup>6</sup>	14724 · 10 <sup>6</sup>	13.00 · 10 <sup>6</sup>	
358	7600	0.25	6.0	2.96	155.0 · 10 <sup>6</sup>	26258 · 10 <sup>6</sup>	20.30 · 10 <sup>6</sup>	
388	7000	0.25	6.5	3.18	225.0 · 10 <sup>6</sup>	37596 · 10 <sup>6</sup>	27.70 · 10 <sup>6</sup>	

<sup>1)</sup> Each lamina set <sup>2)</sup> with E=457.2 mm and cylindrical maximum finish bore

Size	Coupling <sup>2)</sup>		Spacer	
	m [kg]	J [kgm <sup>2</sup> ]	m <sub>R</sub> [kg/mm]	J <sub>R</sub> [kgm <sup>2</sup> /mm]
158	45	0.274	20.28 · 10 <sup>-3</sup>	81 · 10 <sup>-6</sup>
168	69	0.577	27.282 · 10 <sup>-3</sup>	149 · 10 <sup>-6</sup>
188	78	0.711	30.975 · 10 <sup>-3</sup>	191 · 10 <sup>-6</sup>
208	97	1.081	35.118 · 10 <sup>-3</sup>	279 · 10 <sup>-6</sup>
228	123	1.561	44.397 · 10 <sup>-3</sup>	400 · 10 <sup>-6</sup>
248	144	2.109	48.614 · 10 <sup>-3</sup>	524 · 10 <sup>-6</sup>
278	190	3.542	58.694 · 10 <sup>-3</sup>	833 · 10 <sup>-6</sup>
318	306	7.792	79.311 · 10 <sup>-3</sup>	1427 · 10 <sup>-6</sup>
358	405	12.869	104.041 · 10 <sup>-3</sup>	2545 · 10 <sup>-6</sup>
388	525	19.257	120.151 · 10 <sup>-3</sup>	3644 · 10 <sup>-6</sup>

c<sub>l total</sub> = 1 / ((1/c<sub>lE</sub> = 457.2) + ((E - 457.2 mm) / c<sub>lR</sub>))  
m<sub>total</sub> = m + m<sub>R</sub> · (E - 457.2 mm)  
J<sub>total</sub> = J + J<sub>R</sub> · (E - 457.2 mm)



# RIGIFLEX®-HP L

## High-performance steel lamina couplings



### Type with flange hubs

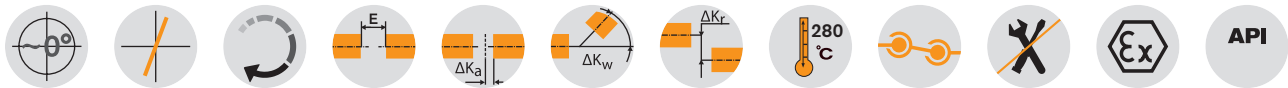

#### Components

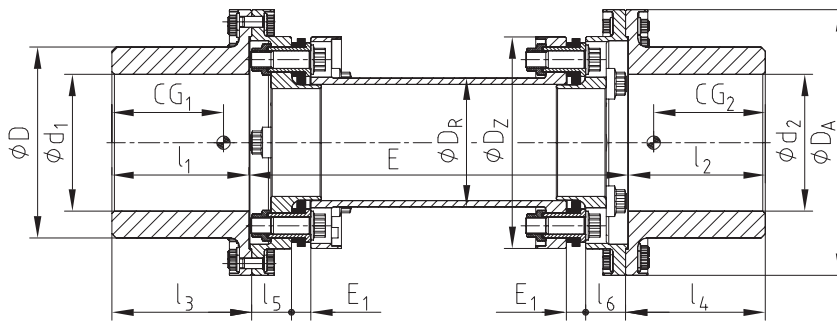

#### RIGIFLEX®-HP type L

Size	Torques [Nm]		Max. finish bore	Dimensions [mm]										
	T <sub>KN</sub>	T <sub>K max</sub>		d <sub>1</sub> , d <sub>2</sub>	D	D <sub>A</sub>	D <sub>Z</sub>	D <sub>R</sub>	E <sub>1</sub>	E	E <sub>min</sub>	CG <sub>1</sub> , CG <sub>2</sub> <sup>2)</sup>	l <sub>1</sub> , l <sub>2</sub>	l <sub>3</sub> , l <sub>4</sub>
158	20000	26000	150	210	310	220	135	17	According to customer specification	265	140	150	163.5	37.5
168	30000	39000	165	230	320	255	155	23		340	148	165	168.5	48.0
188	38000	49400	180	250	335	265	165	23		340	156	180	183.5	48.0
208	50000	65000	200	280	362	298	186	23		340	165	200	203.5	48.0
228	59000	76700	220	310	390	315	199	33		390	179	220	223.5	54.5
248	72000	93600	240	340	420	334	217	33		390	185	235	238.5	54.5
278	115000	149500	270	380	455	380	248	33		390	202	270	273.5	54.5
318	180000	234000	315	445	550	445	280	48		510	246	315	318.5	71.5
358	253000	328900	350	490	600	500	326	48		510	263	350	353.5	71.5
388	330000	429000	380	535	650	545	362	48		510	277	380	383.5	71.5

#### Technical data

Size	Max. speed [rpm]	Perm. displacements			Stiffness figures		
		Angular <sup>1)</sup> ± K <sub>w</sub> [°]	Axial ± K <sub>a</sub> [mm]	Radial <sup>2)</sup> ± K <sub>r</sub> [mm]	each lamina set c <sub>t</sub> [Nm/rad]	Spacer c <sub>tR</sub> [Nm · mm/rad]	Coupling complete <sup>2)</sup> c <sub>tE</sub> = 457.2 [Nm/rad]
158	13800	0.25	3.0	1.56	13.0 · 10 <sup>6</sup>	839 · 10 <sup>6</sup>	1.70 · 10 <sup>6</sup>
168	12300	0.25	3.0	1.45	18.0 · 10 <sup>6</sup>	1535 · 10 <sup>6</sup>	3.00 · 10 <sup>6</sup>
188	11400	0.25	3.3	1.45	28.0 · 10 <sup>6</sup>	1974 · 10 <sup>6</sup>	4.08 · 10 <sup>6</sup>
208	10500	0.25	3.8	1.45	35.0 · 10 <sup>6</sup>	2876 · 10 <sup>6</sup>	5.61 · 10 <sup>6</sup>
228	9700	0.25	4.0	1.34	39.5 · 10 <sup>6</sup>	4123 · 10 <sup>6</sup>	7.77 · 10 <sup>6</sup>
248	9000	0.25	4.2	1.34	60.0 · 10 <sup>6</sup>	5410 · 10 <sup>6</sup>	10.70 · 10 <sup>6</sup>
278	8300	0.25	4.5	1.34	80.0 · 10 <sup>6</sup>	8592 · 10 <sup>6</sup>	15.60 · 10 <sup>6</sup>
318	6900	0.25	5.2	1.13	105.0 · 10 <sup>6</sup>	14724 · 10 <sup>6</sup>	26.90 · 10 <sup>6</sup>
358	6300	0.25	6.0	1.13	155.0 · 10 <sup>6</sup>	26258 · 10 <sup>6</sup>	41.20 · 10 <sup>6</sup>
388	5800	0.25	6.5	1.13	225.0 · 10 <sup>6</sup>	37596 · 10 <sup>6</sup>	61.30 · 10 <sup>6</sup>

<sup>1)</sup> Each lamina set <sup>2)</sup> with E=457.2 mm and cylindrical maximum finish bore

Size	Coupling <sup>2)</sup>		Spacer	
	m [kg]	J [kgm <sup>2</sup> ]	m <sub>R</sub> [kg/mm]	J <sub>R</sub> [kgm <sup>2</sup> /mm]
158	80	0.717	20.28 · 10 <sup>-3</sup>	81 · 10 <sup>-6</sup>
168	115	1.327	27.282 · 10 <sup>-3</sup>	149 · 10 <sup>-6</sup>
188	135	1.759	30.975 · 10 <sup>-3</sup>	191 · 10 <sup>-6</sup>
208	175	2.771	35.118 · 10 <sup>-3</sup>	279 · 10 <sup>-6</sup>
228	235	4.525	44.397 · 10 <sup>-3</sup>	400 · 10 <sup>-6</sup>
248	285	6.417	48.614 · 10 <sup>-3</sup>	524 · 10 <sup>-6</sup>
278	375	10.381	58.694 · 10 <sup>-3</sup>	833 · 10 <sup>-6</sup>
318	642	24.810	79.311 · 10 <sup>-3</sup>	1427 · 10 <sup>-6</sup>
358	812	38.404	104.041 · 10 <sup>-3</sup>	2545 · 10 <sup>-6</sup>
388	1016	57.062	120.151 · 10 <sup>-3</sup>	3644 · 10 <sup>-6</sup>

Ordering example:	RIGIFLEX®-HP 188	L	Ø 160	Ø 180	457.2
	Coupling size	Type	Bore d <sub>1</sub>	Bore d <sub>2</sub>	Shaft distance dimension E

RADEX®-N

Lamina couplings

RIGIFLEX®-N

RIGIFLEX®-HP

**Morskate®**



Any questions? Please contact us.

**Morskate Aandrijvingen BV**

Oosterveldsingel 47A  
7558 PJ Hengelo (Ov)  
The Netherlands

NL

T +31 (0)74 - 760 11 11  
info@morskateaandrijvingen.nl  
www.morskateaandrijvingen.nl

DE

T +49 692 - 222 34 95  
info@morskateantriebstechnik.de  
www.morskateantriebstechnik.de

EN

T +31 (0)74 - 760 11 11  
info@morskatedrivetechnology.com  
www.morskatedrivetechnology.com